

5. Sample Circuits

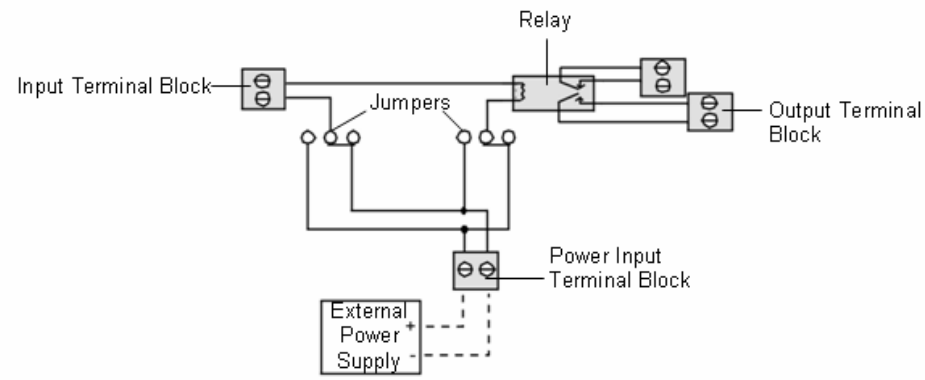

Common Polarity Configured with Jumpers

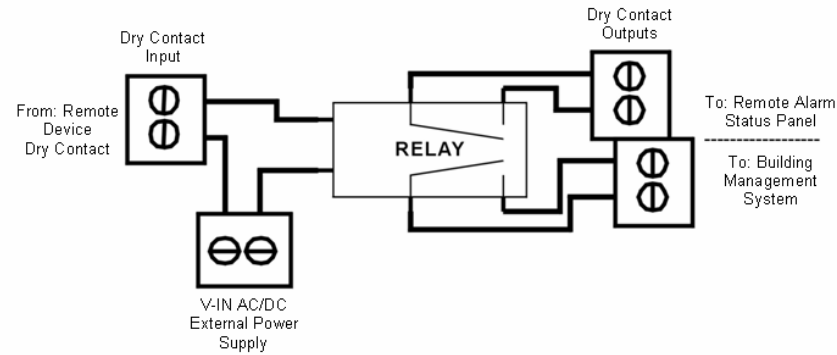

Specifications

Power	
RR5x10, RR10x20*	24VAC/VDC (±10%) @ 500mA max.; requires power supply: WA-DC-24-ST (not included)
RR5x10-48*	48VAC/VDC (±10%) @ 250mA max.; requires power supply (not included)
RR10x20-48*	48VAC/VDC (±10%) @ 250mA max.; requires power supply (not included)
RR20x40	100/120/240VAC @ 500mA max., 50/60Hz; hardwired power supply
Relay Outputs	
RR5x10	10 Form A, 1A @ 24VDC, 0.5A resistive @ 120VAC
RR10x20	20 Form A, 1A @ 24VDC, 0.5A resistive @ 120VAC
RR20x40	40 Form A, 1A @ 24VDC, 0.5A resistive @ 120VAC
Isolation	1000Vrms
Operating Environment	
Temperature	32° to 122°F (0° to 50°C).
Humidity	5% to 95% RH, non-condensing
Altitude	15,000ft (4,572m) max.
Storage Temperature	-4° to 158°F (-20° to 70°C)
Dimensions	
RR5x10	10.5"W x 8.0"H x 2.0"D (267mmW x 203mmH x 51mmD)
RR10x20	10.5"W x 8.0"H x 2.0"D (267mmW x 203mmH x 51mmD)
RR20x40	12.0"W x 14.0"H x 4.0"D (305mmW x 356mmH x 102mmD)
Weight	
RR5x10, RR10x20	5.0 lbs (2.27 kg)
RR20x40	12.0 lbs (5.45 kg)
Mounting	Vertical wall mount
Certifications	CE; RoHS compliant

*Other voltages available upon request



FORT COLLINS CO
970 484-6510
970 484-6650 FAX
WWW.RLETECH.COM

©2008 RLE Technologies 13104 Rev 5.4 (07/2008)

Although the information contained in this document is believed to be accurate and correct, RLE Technologies assumes no responsibility, and disclaims all liability, for any damages resulting from the use of this information or any error or omission in this document. RLE Technologies does not warrant, guarantee, or make any representations as to the performance, fitness for use, safety, or reliability of any existing or future wiring, equipment, additions or modifications to equipment, or any other component of the original or modified system. Specifications are subject to change without notice.



RR SERIES

RELAY REPLICATOR

USER GUIDE

RR SERIES

The Relay Replicator converts single dry contact signals into multiple isolated dry contact signals. This allows the dry contact signal to be routed to multiple systems or devices. Each input causes a relay on the Relay Replicator to either activate or to deactivate depending upon the input contact state. In turn, the Relay Replicator provides two outputs for each input. The relays provide 1,000V of electrical isolation. The Relay Replicator is jumper configurable to select inputs with either a positive or negative common.

The RR5x10, RR10x20 and RR20x40 products come in a metal enclosure that can be wall mounted. The RR10x20 contains one circuit board with 10 DPST relays. The RR5x10 uses the same circuit board except inputs 6-10 are not populated with components – only the first 5 inputs are available. The RR20x40 uses two circuit boards.



1. Relay Replicator Installation

The Relay Replicator is a wall mounted device. To secure the device to the wall, first remove the aluminum back panel and all electronics from the enclosure. There are knockouts on the top and bottom of the enclosure designed to accommodate 0.5 inch (12.7mm) conduit. Remove as many as necessary. There are two holes in the top back of the unit. Use drywall anchors to secure the unit to the wall. Put two more drywall anchors through the two holes in the bottom back of the unit. Reinstall the back panel and reconnect the electronics.

2. Power

The RR5x10 and RR10x20 require an external 24VAC/VDC or 48VAC/VDC (RR5x10-48 and RR10x20-48) power supply. Use RLE Technologies wall adapter power supply (part #WA-DC-24-ST) for 24V units. The RR20x40 is hardwired and requires an external 85-264VAC, 50/60Hz power input.



WARNING!

A dedicated circuit breaker must be provided in the building within close proximity to the RR20x40, and be clearly marked as the disconnecting device for this unit.

3. Connections and Settings

The Relay Replicator duplicates any dry contact from any device connected to the input terminal blocks. Each input, when activated, will activate the corresponding output relays. The output relays are DPST. The outputs are isolated from each other.

The inputs can be connected in common by installing the necessary jumpers. This greatly reduces the number of wires that are terminated on the board(s). This may not be possible in all configurations. The terminal blocks will only accept two 20AWG wires.

Make sure the jumpers for channels 1-5 (JP1-JP11) are all set for either a positive (POS, P) or negative (NEG, N) common. If the unit is a 10x20 model, make sure the jumpers for channels 6-10 (JP12-JP22) are all set for either a positive (POS,P) or negative (NEG,N) common.

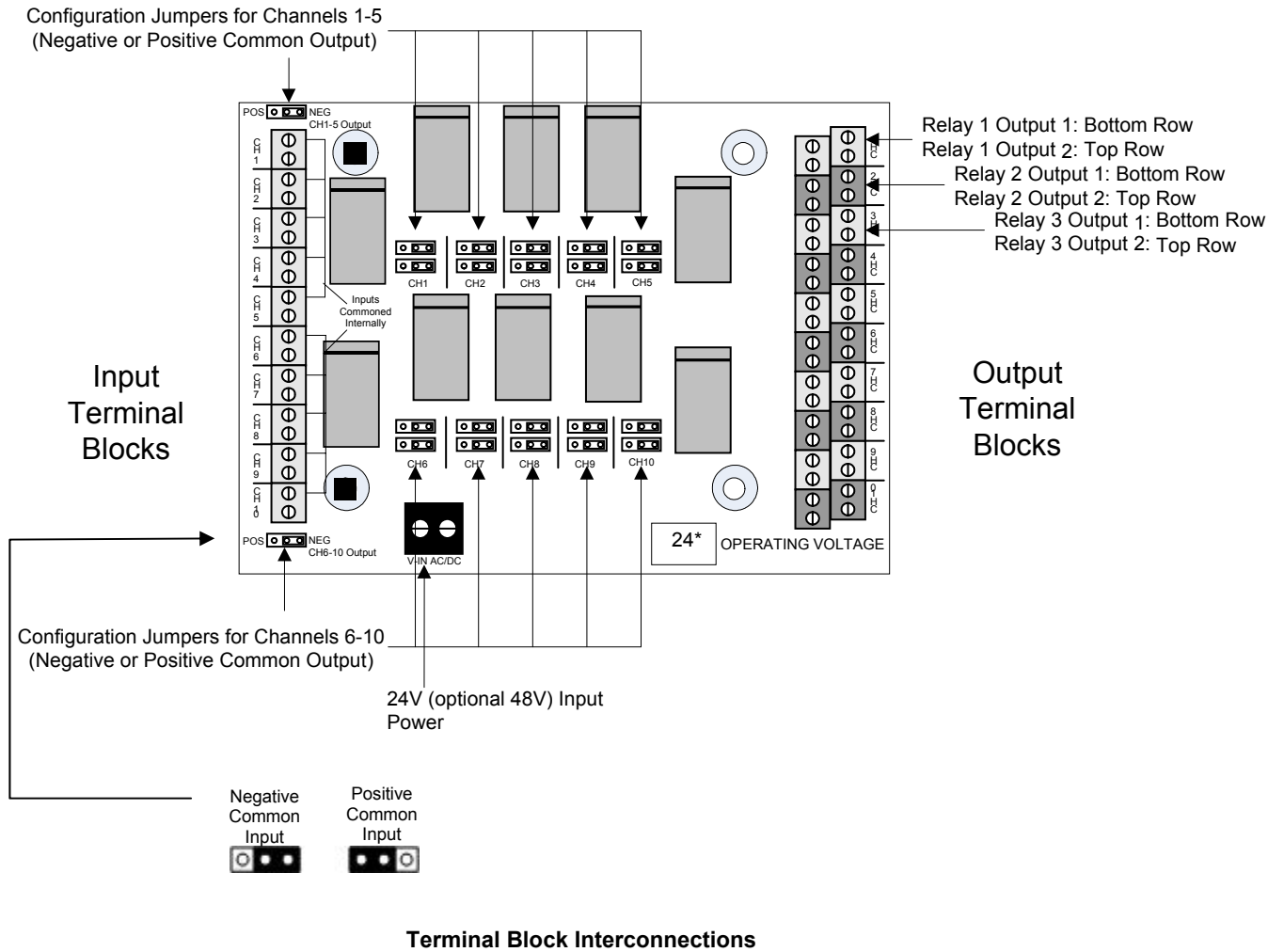

4. Typical Applications

The Relay Replicator was designed to give two isolated Dry Contact Outputs, from one relay. Once the Dry Contact activates or changes state, the Relay Replicator will provide two isolated Dry Contact Outputs.

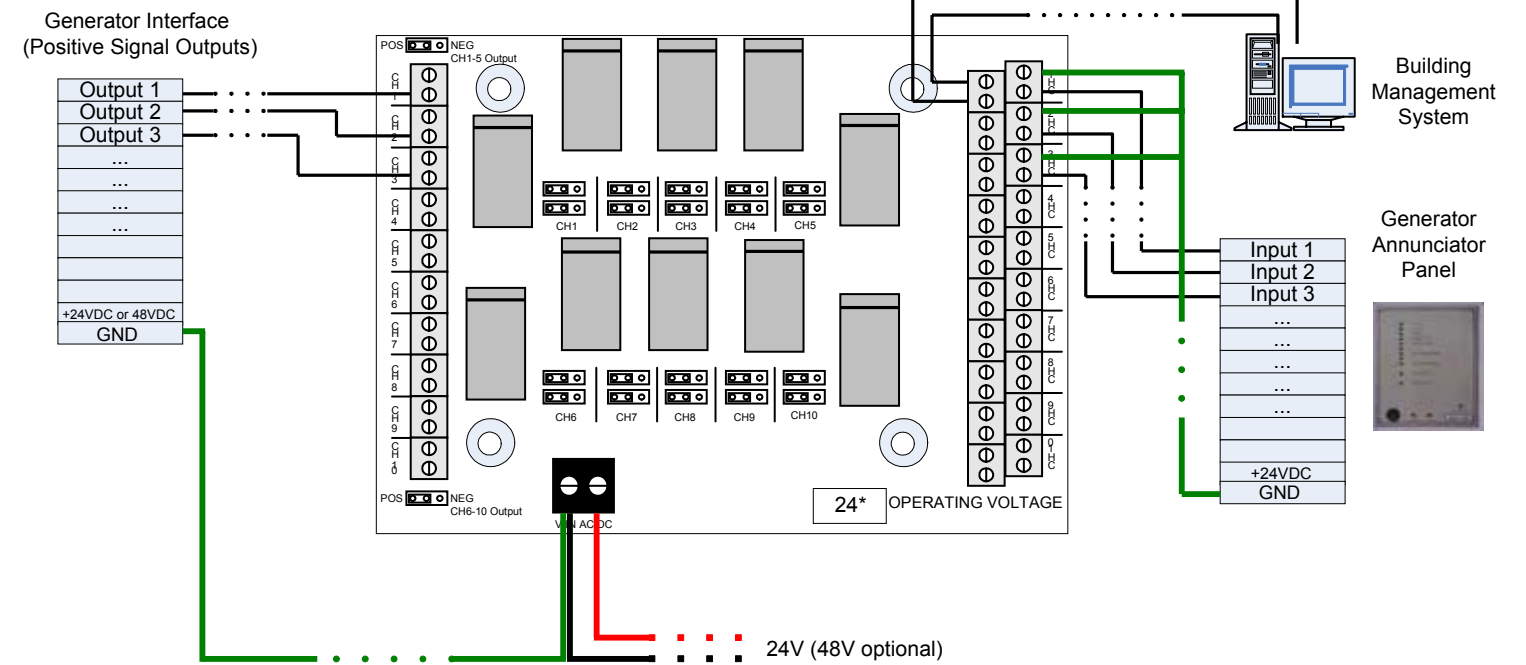
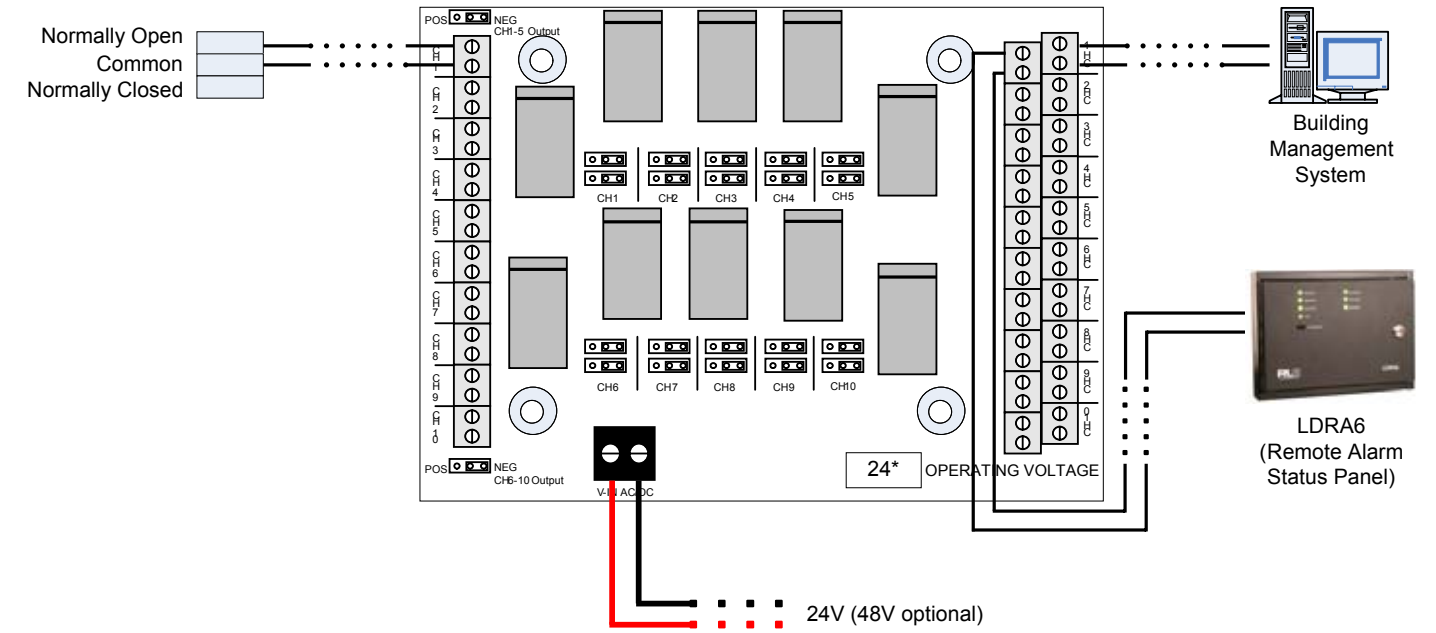

***NOTE:**
24V is normal operation voltage, with a 48V option. Check the voltage of your unit before connecting to a power source.